

BURNSIDE

ASSEMBLY INSTRUCTIONS

D-FRAME - STARTER :: 292/299 - DF - STR

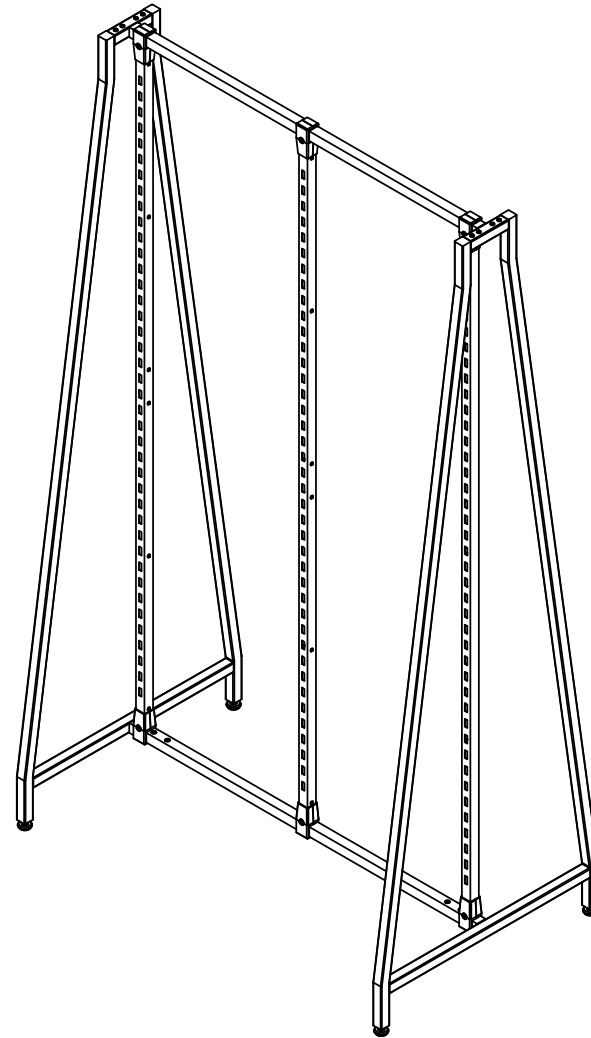

PART LIST:



4X. UPRIGHT
- END



2X. SIDE
UPRIGHT



1X. CENTER
UPRIGHT

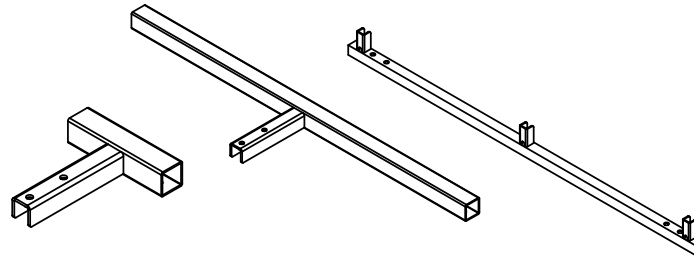

2X. TOP RAIL
- END

2X. BOTTOM RAIL
- END

2X. RAIL

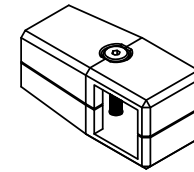

6X. CONNECTOR

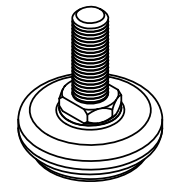

4X. 3/8"-16TPI LEVELER

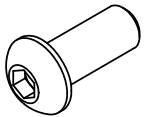

16X. SBHC SCREW
1/4-20 X 0.625"

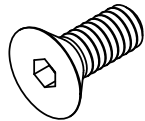

8X. SOCKET
COUNTERSUNK
HEAD SCREW
1/4"-20 X 0.625"

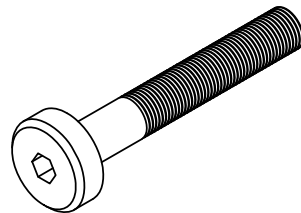

6X. JOINT CONNECTOR
BOLT 1/4"-20 X 1 5/8"

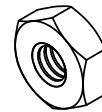

6X. HEX NUT
1/4"-20 TPI

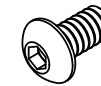

24X. SBHC SCREW
#10-24 X 0.375"

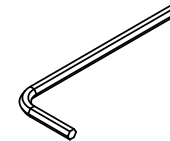

1X. L - KEY
FOR 1/4-20

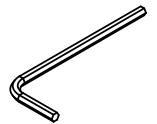

1X. L - KEY FOR
#10

STEP 1:

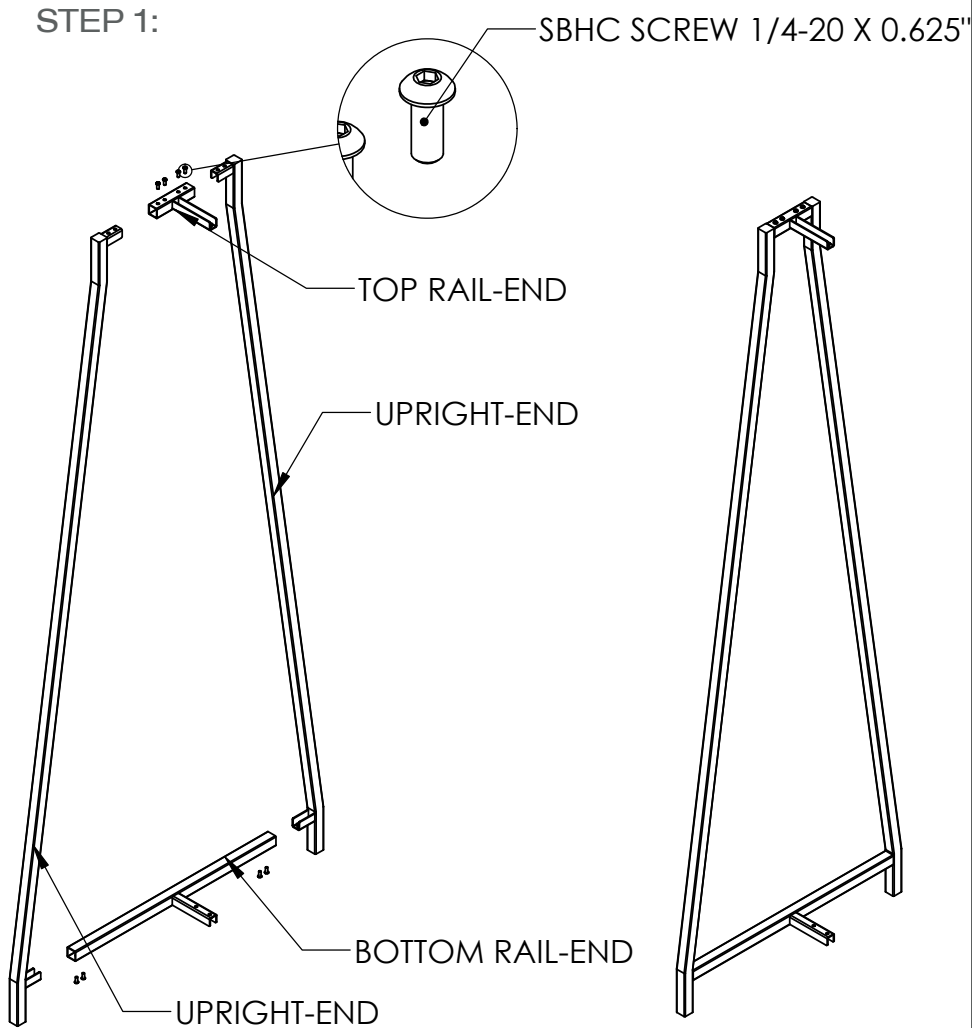

STEP 2:

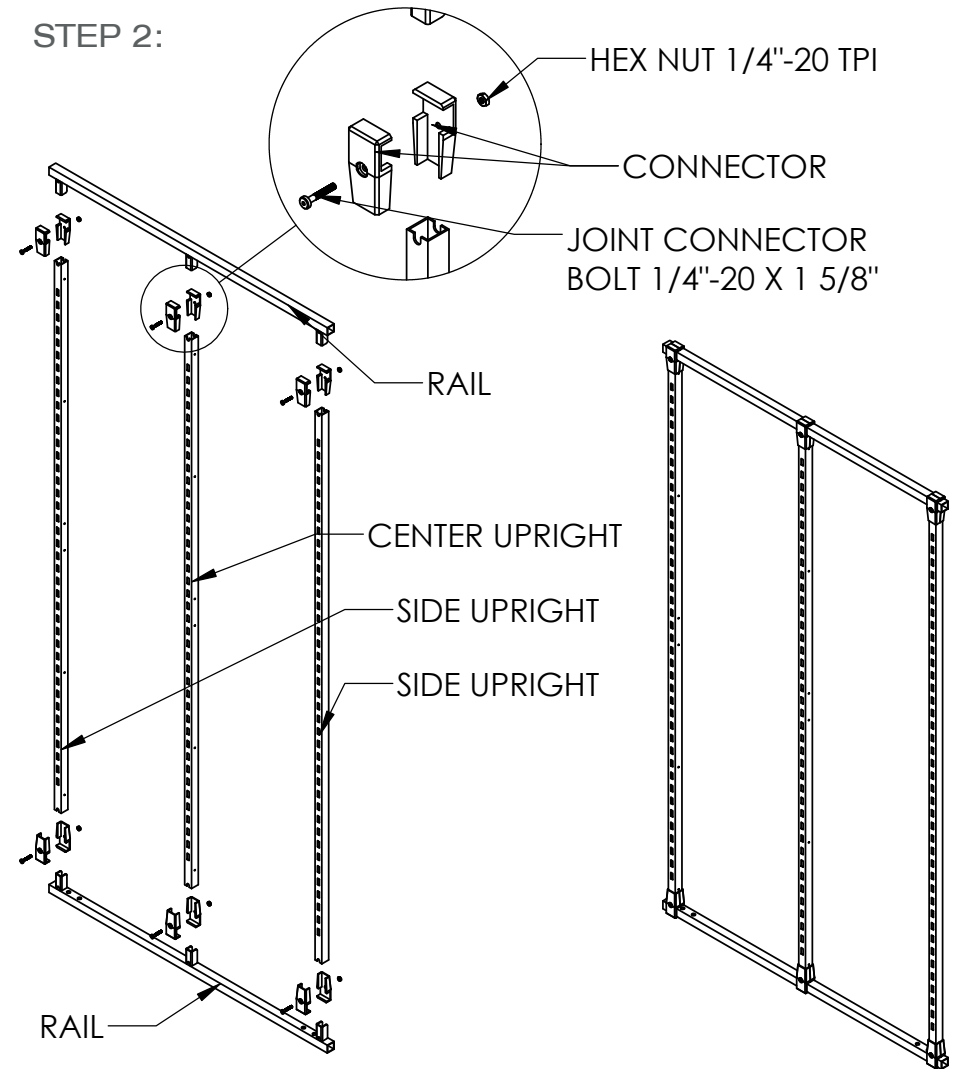

STEP 3:

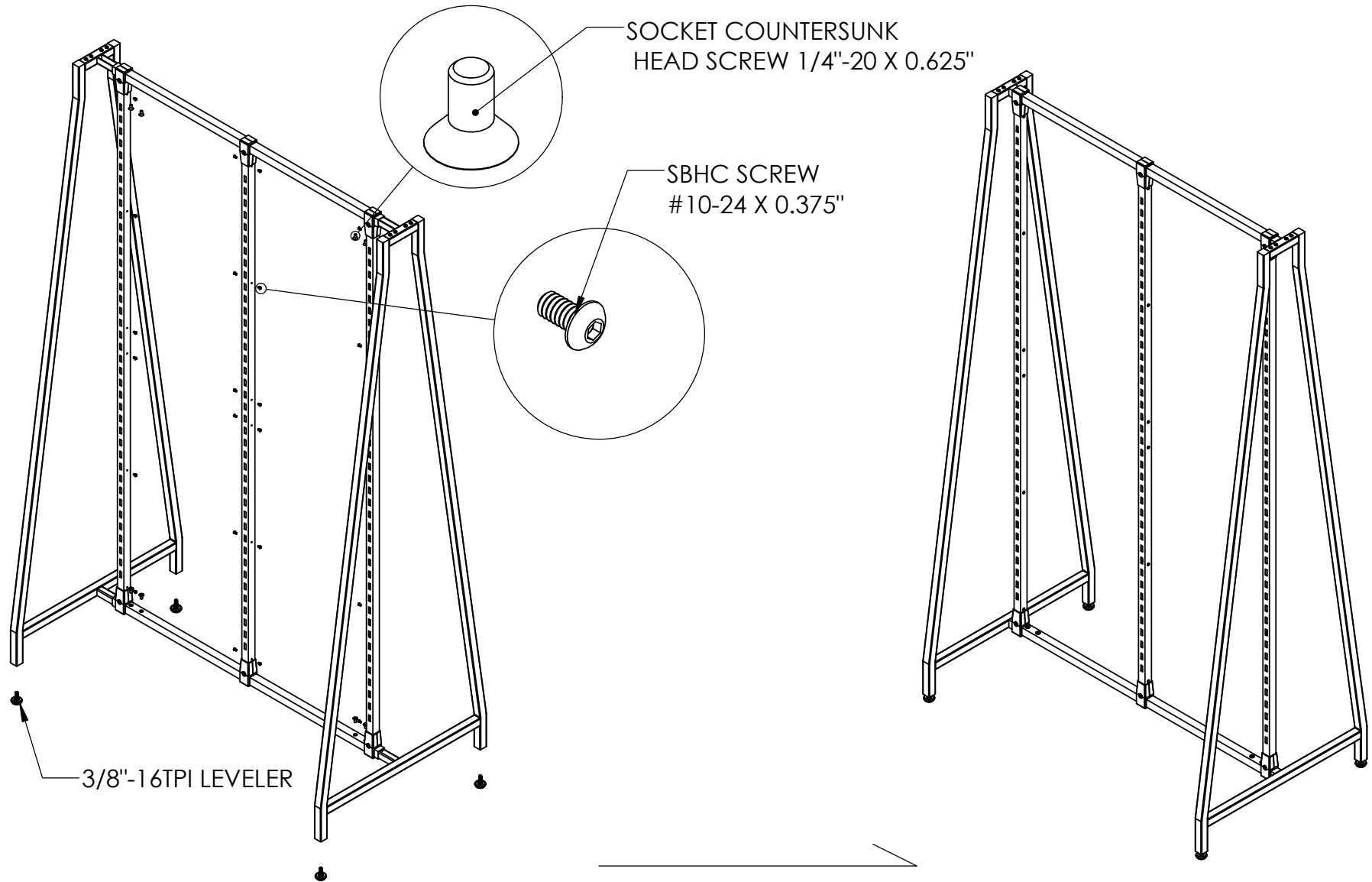

STEP 1: ATTACH THE BRACKETS

Using an Allen wrench, securely screw in each of the four brackets to the inside of the fixture frame. Leave slightly loose for extra wiggle room (these can be tightened later).

STEP 2: REMOVE HEAD

Remove the head/thumb screw from each bracket. This will allow you to mount the back panel.

STEP 3: ALIGN THE HOLES

Align the corresponding holes on the back panel with each of the mounting brackets on the fixture. Take care to properly line them up.

STEP 4: SECURE THE BACK PANEL

Place a silicon washer on each side of the back panel, and then use the head/thumb screw to fasten the back panel in place. Ensure the back panel is securely attached.

