

BURNSIDE

ASSEMBLY INSTRUCTIONS

W-FRAME - STARTER :: 292/299 - WF- STR

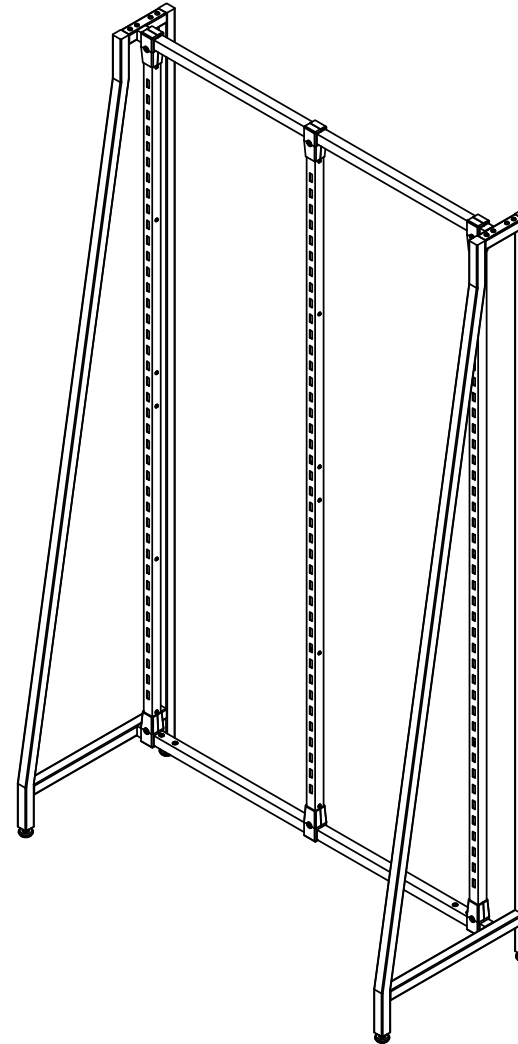

PART LIST:

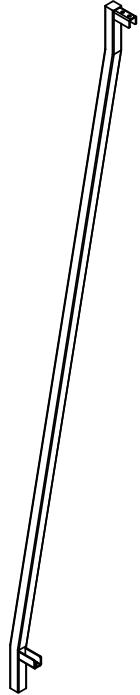

2X. SIDE FRAME UPRIGHT - A



2X. SIDE FRAME UPRIGHT - B



1X. CENTER UPRIGHT



2X. SIDE UPRIGHT

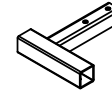

1X. SIDE FRAME TOP RAIL - L

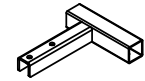

1X. SIDE FRAME TOP RAIL - R

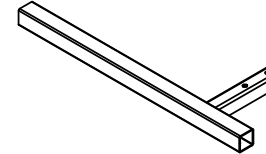

1X. SIDE FRAME BOTTOM RAIL - L

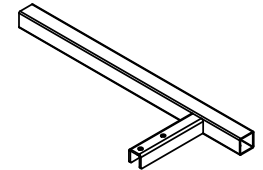

1X. SIDE FRAME BOTTOM RAIL - R



16X. SBHC SCREW 1/4"-20 X 0.625"



8X. SCHC SCREW 1/4"-20 X 0.625"



24X. SBHC SCREW #10-24 X 0.375"

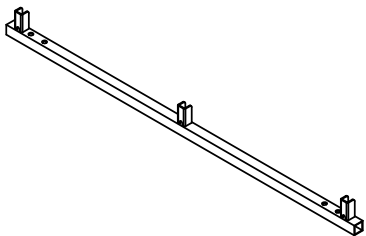

2X. CENTER FRAME CROSS RAIL

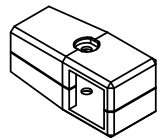

6X. SET CONNECTOR

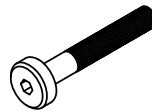

6X. JOINT CONNECTOR BOLT 1/4"-20 X 1.625"



6X. HEX NUT 1/4"-20 UNC

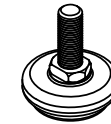

4X. 3/8"-16 LEVELER

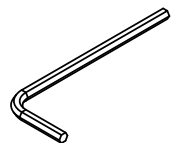

1X. L-KEY FOR 1/4"
1X. L-KEY FOR #10

STEP 1:

ASSEMBLE SIDE FRAME - LEFT.

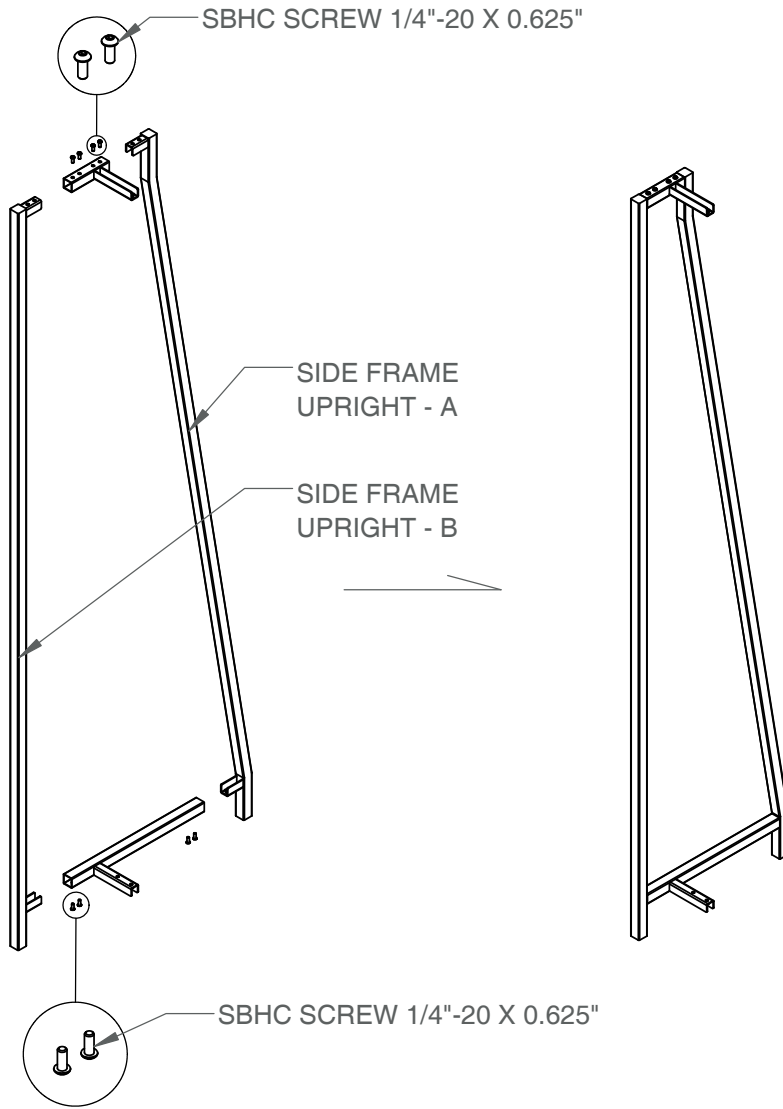

STEP 2:

ASSEMBLE SIDE FRAME - RIGHT.

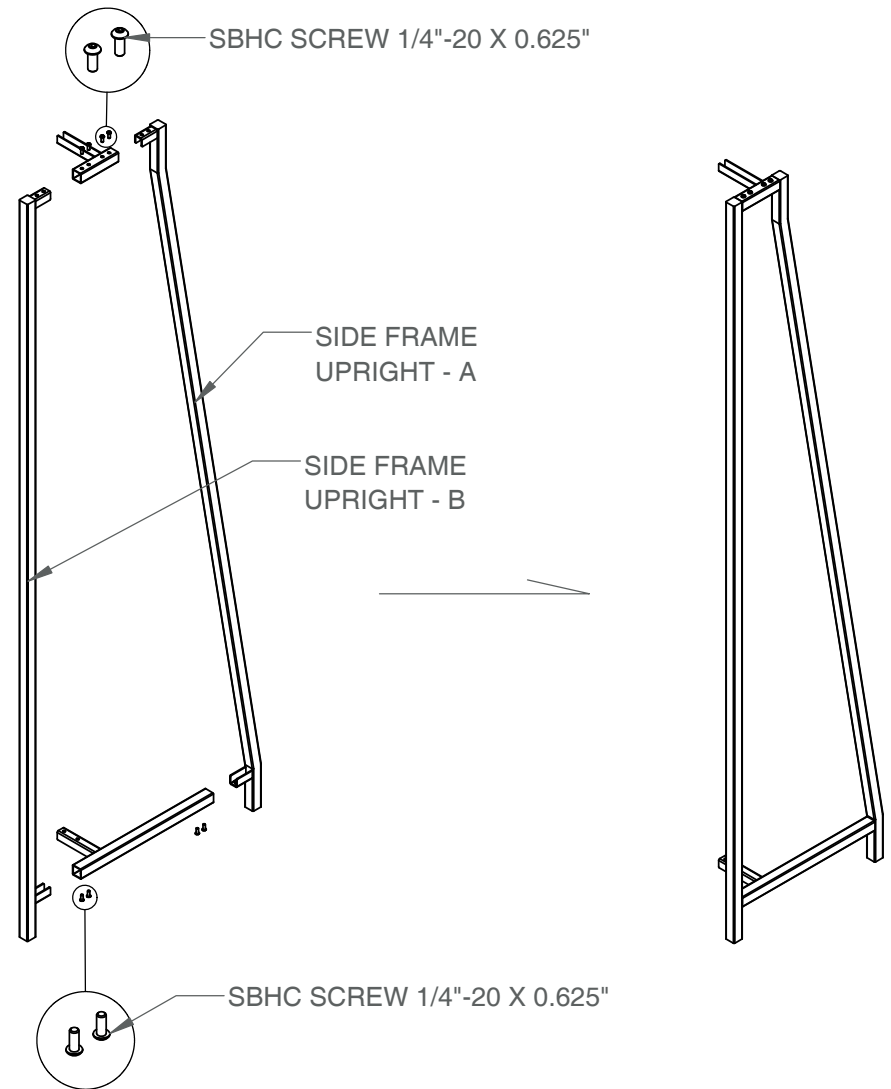

STEP 3:

ASSEMBLE CENTER FRAME.

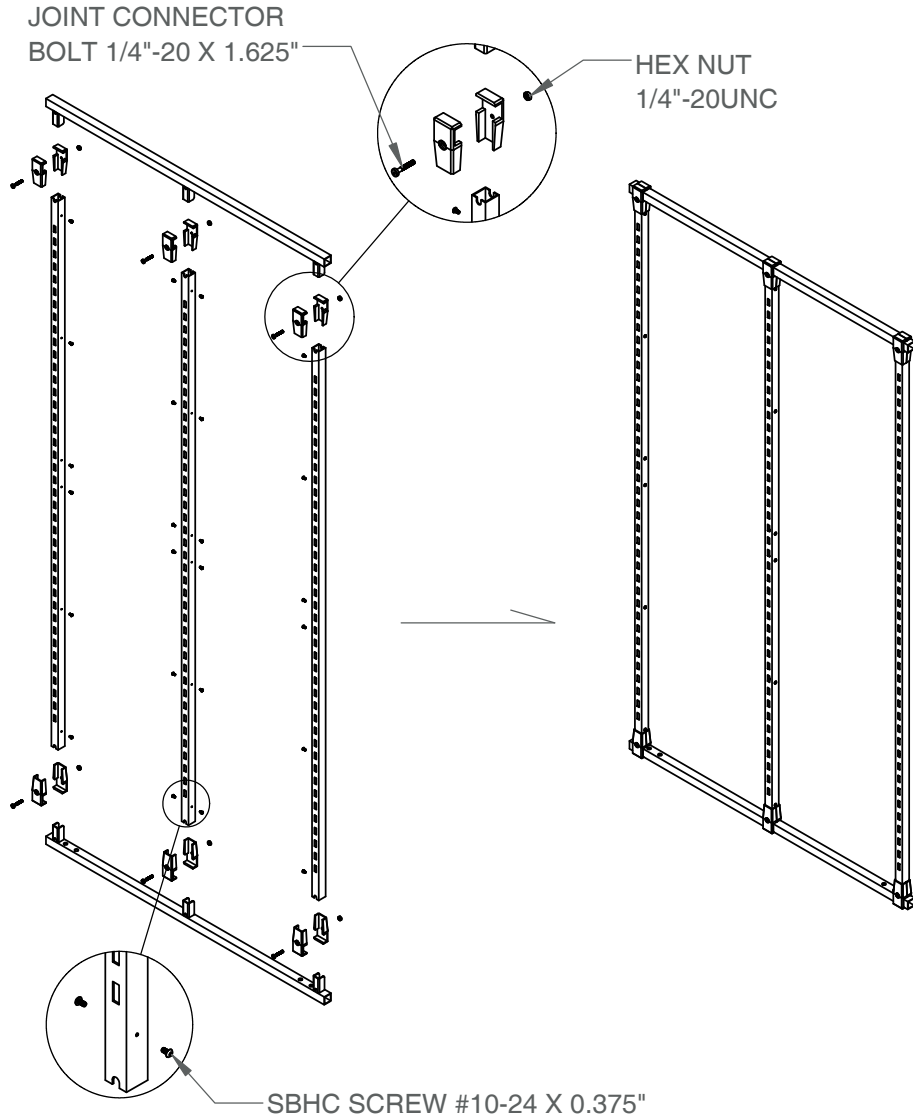

STEP 4:

COMPLETED FIXTURE

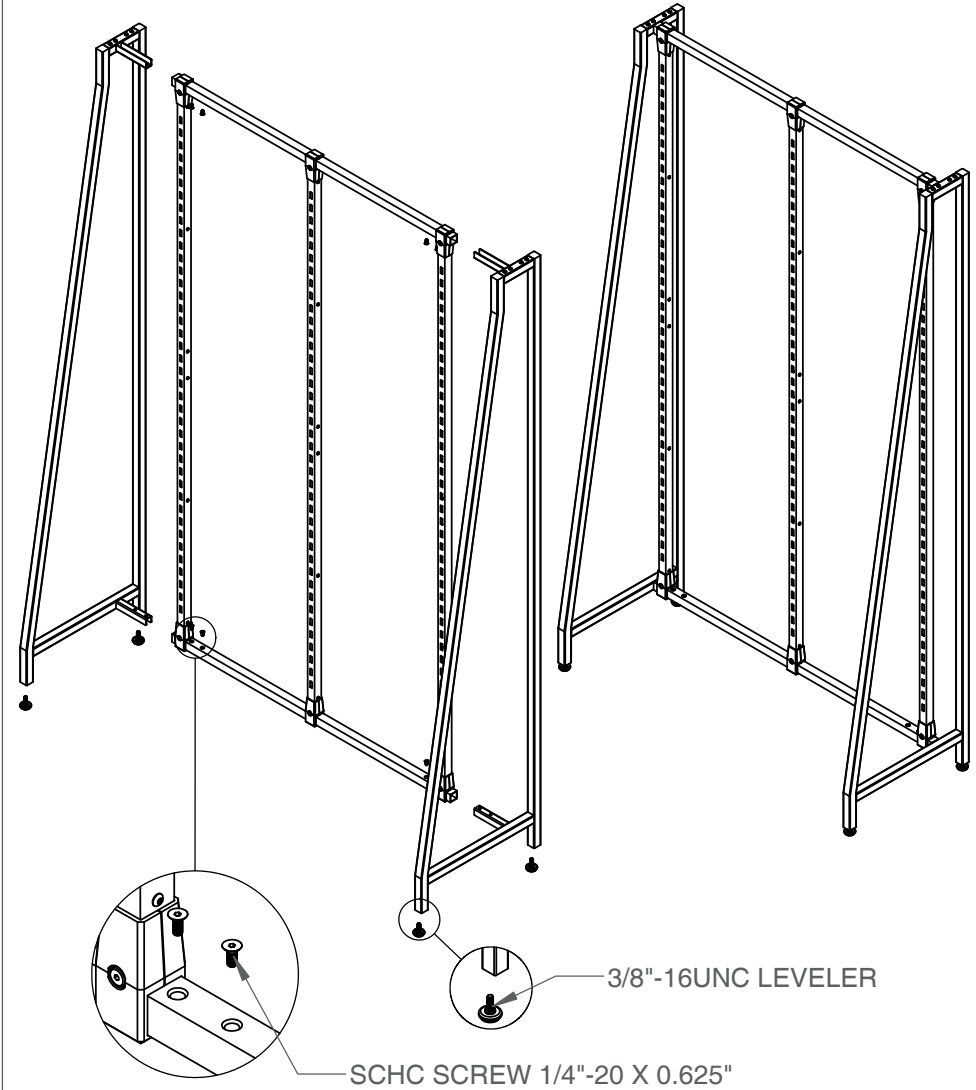

STEP 1: ATTACH THE BRACKETS

Using an Allen wrench, securely screw in each of the four brackets to the inside of the fixture frame. Leave slightly loose for extra wiggle room (these can be tightened later).

STEP 2: REMOVE HEAD

Remove the head/thumb screw from each bracket. This will allow you to mount the back panel.

STEP 3: ALIGN THE HOLES

Align the corresponding holes on the back panel with each of the mounting brackets on the fixture. Take care to properly line them up.

STEP 4: SECURE THE BACK PANEL

Place a silicon washer on each side of the back panel, and then use the head/thumb screw to fasten the back panel in place. Ensure the back panel is securely attached.

